

Agilent 43961A Impedance Test Kit
Service Manual



Agilent Part No. 43961-90040
Printed in JAPAN June 2000

Notice

The information contained in this document is subject to change without notice.

This document contains proprietary information that is protected by copyright. All rights are reserved. No part of this document may be photocopied, reproduced, or translated to another language without the prior written consent of the Agilent Technologies.

Agilent Technologies Japan, Ltd.
Component Test PGU-Kobe
1-3-2, Murotani, Nishi-ku, Kobe-shi,
Hyogo, 651-2241 Japan

Manual Printing History

The manual printing date and part number indicate its current edition. The printing date changes when a new edition is printed. (Minor corrections and updates that are incorporated at reprint do not cause the date to change.) The manual part number changes when extensive technical changes are incorporated.

September 1994 First Edition (part number: 43961-90030)
June 2000 Second Edition (part number: 43961-90040)

Safety Summary

The following general safety precautions must be observed during all phases of operation, service, and repair of this instrument. Failure to comply with these precautions or with specific **WARNINGS** given elsewhere in this manual violates safety standards of design, manufacture, and intended use of the instrument.

The Agilent Technologies assumes no liability for the customer's failure to comply with these requirements.

DO NOT Operate In An Explosive Atmosphere

Do not operate the instrument in the presence of flammable gasses or fumes. Operation of any electrical instrument in such an environment constitutes a safety hazard.

Keep Away From Live Circuits

Operating personnel must not remove instrument covers. Component replacement and internal adjustments must be made by qualified maintenance personnel. Do not replace components with the power cable connected. Under certain conditions, dangerous voltages may exist even with the power cable removed. To avoid injuries, always disconnect power and discharge circuits before touching them.

DO NOT Service Or Adjust Alone

Do not attempt internal service or adjustment unless another person, capable of rendering first aid and resuscitation, is present.

DO NOT Substitute Parts Or Modify Instrument

Because of the danger of introducing additional hazards, do not substitute parts or perform unauthorized modifications to the instrument. Return the instrument to a Agilent Technologies Sales and Service Office for service and repair to ensure the safety features are maintained.

Dangerous Procedure Warnings

The voltage levels found in this test fixture when used with the intended instruments do not warrant more than normal safety precautions for operator safety.

Operating Precaution

Do not exceed the operating input power, voltage, and current level and signal type appropriate for the instrument being used, refer to your instrument's operation manual.

Caution



Electrostatic discharge (ESD) can damage the highly sensitive microcircuits in your instrument. ESD damage is most likely to occur as the test fixtures are being connected or disconnected. Protect them from ESD damage by wearing a grounding strap that provides a high resistance path to ground. Alternatively, ground yourself to discharge any static charge built-up by touching the outer shell of any grounded instrument chassis before touching the test port connectors.

Use a work station equipped with an anti-static work surface.

Warranty

This Agilent Technologies instrument product is warranted against defects in material and workmanship for a period of one year from the date of shipment. During the warranty period, Agilent Technologies will, at its option, either repair or replace products that prove to be defective.

For warranty service or repair, this product must be returned to a service facility designated by Agilent Technologies. Buyer shall prepay shipping charges to Agilent Technologies and Agilent Technologies shall pay shipping charges to return the product to Buyer. However, Buyer shall pay all shipping charges, duties, and taxes for products returned to Agilent Technologies from another country.

Agilent Technologies warrants that its software and firmware designated by Agilent Technologies for use with an instrument will execute its programming instruction when properly installed on that instrument. Agilent Technologies does not warrant that the operation of the instrument, or software, or firmware will be uninterrupted or error free.

Limitation Of Warranty

The foregoing warranty shall not apply to defects resulting from improper or inadequate maintenance by Buyer, Buyer-supplied software or interfacing, unauthorized modification or misuse, operation outside the environmental specifications for the product, or improper site preparation or maintenance.

No other warranty is expressed or implied. Agilent Technologies specifically disclaims the implied warranties of merchantability and fitness for a particular purpose.

Exclusive Remedies

The remedies provided herein are buyer's sole and exclusive remedies. Agilent Technologies shall not be liable for any direct, indirect, special, incidental, or consequential damages, whether based on contract, tort, or any other legal theory.

Assistance

Product maintenance agreements and other customer assistance agreements are available for Agilent Technologies products.

For any assistance, contact your nearest Agilent Technologies Sales and Service Office. Addresses are provided at the back of this manual.

APC-7® is a U.S. registered trademark of the Bunker Ramo Corporation.

General Information

Introduction

This manual provides information about the contents, operation and service for the 43961A Impedance Test Kit.

Contents

Table 1-1 shows the contents of the 43961A Impedance Test Kit.

Table 1-1. Contents of the 43961A

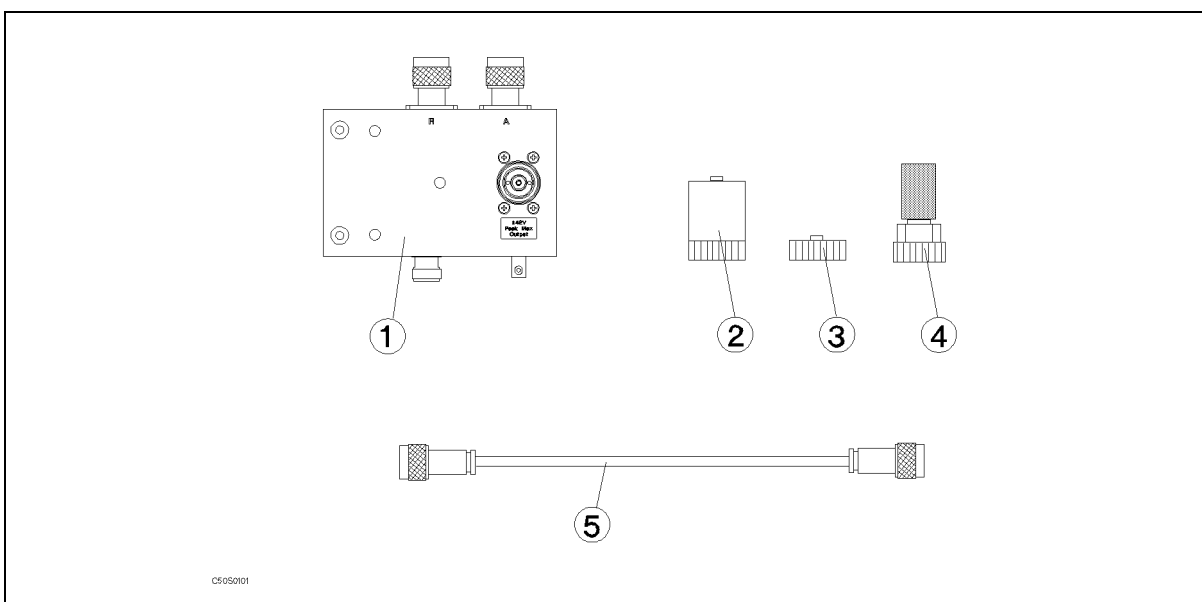

No.	Description	Qty.	Agilent Part Number
1	Impedance Test Adapter	1	43961-61001
2	0 S Calibration Standard	1	04191-85302
3	0 Ω Calibration Standard	1	04191-85300
4	50 Ω Calibration Standard	1	04191-85301
5	N(m)-N(m) cable	1	41951-61602
	Carrying Case ¹	1	43961-60001

¹ This part is not shown in above.

Operation

The 43961A has been designed to operate specifically with the 4396A/B and 4395A Network/Spectrum/Impedance Analyzer.

- To operate the 43961A with the 4396B see 4396B option 010 Operating Handbook (Agilent PN: 04396-90006 written in English or Agilent PN: 04396-97006 written in Japanese)
- To operate the 43961A with the 4396B see 4396B option 010 Operating Handbook (Agilent PN: 04396-90036 written in English or Agilent PN: 04396-97036 written in Japanese)
- To operate the 43961A with the 4395A see 4395A Operation Manual (Agilent PN: 04395-90000 written in English or Agilent PN: 04395-97000 written in Japanese)

Service

Introduction

This chapter provides the replaceable parts and functional check for the 43961A Impedance Test Kit.

Replaceable Parts

Table 2-1 and Table 2-2 list the replaceable parts. The parts listed in these tables can be ordered from your nearest Agilent Technologies office. Ordering information should include the Agilent part number and the quantity required.

Table 2-1. Replaceable Parts List (1/2)

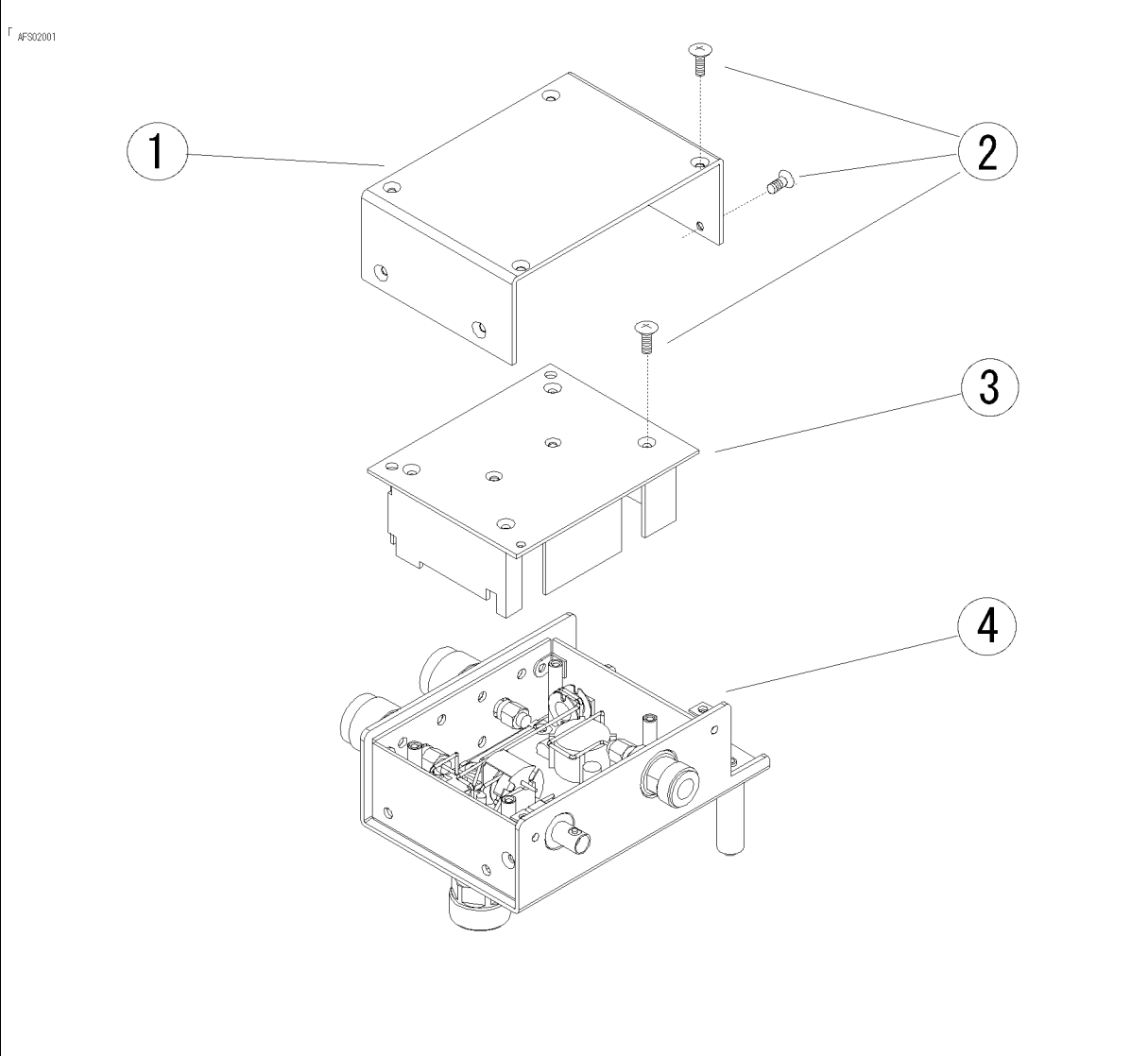

Reference Designator	Agilent Part Number	Qty.	Description
1	43961-04002	1	Bottom Cover
2	0515-0907	12	Screw M3x0.5, Flat Head
3	43961-00602	1	Case, Shield
4	NA	1	Fixture Assembly

Table 2-2. Replaceable Parts List (2/2)

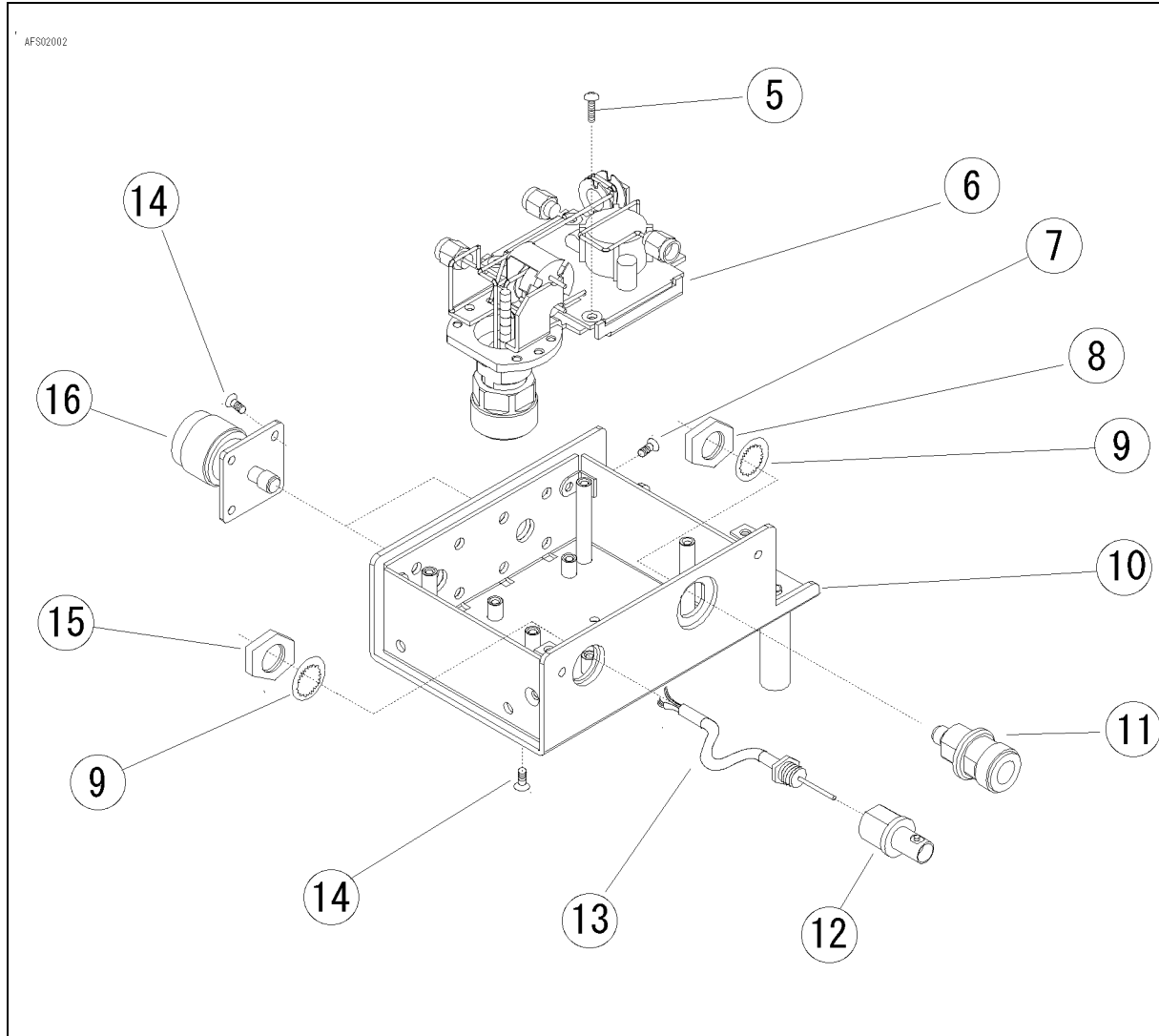

Reference Designator	Agilent Part Number	Qty.	Description
5	0515-1550	4	Screw M3 L8, Pan Head
6	NA ¹	1	APC-7® and board assembly
7	0515-0914	4	Screw M3 0.5, Pan Head
8	NA	1	Nut (included in N-SMA connector "11")
9	2190-0054	1	Washer
10	43961-04001	2	Chassis
11	1250-2205	1	Connector, N(f)-SMA(f)
12	1250-0102	1	Connector, BNC(f)
13	43961-61621	1	Cable Ass'y with BNC Center Pin
14	0515-0907	4	Screw M3 0.5, Pan Head
15	2950-0054	1	Nut
16	1250-2468	2	Connector, N(m)-SMA(f)

¹ The part is not replaceable. Contact your nearest Agilent Technologies service office for part number of whole assembly.

Functional Check

You can check the impedance test kit is working correctly by performing the following procedures.

Table 2-3. Required Equipment

Equipment	Required Model
Analyzer	4396A
Multimeter	3458A or 3478A

Impedance Measurement Functional Check

1. Connect the 43961A to the 4396A.
2. Press **Preset**.
3. Press **Meas**, **ANALYZER TYPE**, and **IMPEDANCE ANALYZER**.
4. Press **System**, **SERVICE MENU**, **TEST**, **MISC TEST**, and **CONT**.
5. Follow the instructions displayed on the 4396A CRT to connect and measure the standards (0 S, 0 Ω , and 50 Ω) furnished in the 43961A. The 4396A checks the operation of the 43961A automatically.

DC Bias Functional Check

1. Connect the test leads to the multimeter's high and low terminals.
2. Set the multimeter to the resistance measurement mode.
3. Connect the APC7-N(f) adapter to the 43961A's APC-7 connector.
4. Connect the tip of one test lead to the center conductor of the impedance test kit's DC SOURCE Input. Connect the other test lead to the center conductor of the APC7-N(f) adapter.
5. Check the multimeter reading is 2 k Ω \pm 200 Ω .